

Installation and Operation Manual

AW-BK901 Conventional Reflective Beam Detector

Product Safety

To prevent severe injury and loss of life or property, read the instruction carefully before installing the beam detector to ensure proper and safe operation of the system.



European Union directive

2012/19/EU (WEEE directive): Products marked with this symbol cannot be disposed of as unsorted municipal waste in the European Union. For proper recycling, return this product to your local supplier upon the purchase of equivalent new equipment, or dispose of it at designated collection points. For more information please visit the website at www.recyclethis.info

Table of Content

Introduction	4
Overview	4
Main Features	4
Technical Specification	5
Product Appearance	6
Principle of the Beam Detector	6
Installation Procedures	6
Mounting Details	7
LED Indicators	7
Mounting Preparation	7
Mounting of the Beam Detector	8
Mounting of the Reflective Mirror	8
Cabling Details	9
Programming Sensitivity and Span	9
To View the Detector Parameter	9
To adjust the Sensitivity	10
To adjust the Span (Distance)	10
Commissioning Beam Detector	11
Commissioning Preparation	12
Step 1: Entering Commissioning Method	12
Step 2: Sightline Alignment Procedure	12
Step 3: Acceptable Adjustment Procedure	12
Step 4: Finalizing Installation	12
Step 5: Testing Fire Signal	13
Step 6: Testing Fault Signal	13
Other Function	13
Maintenance	14
Troubleshooting Guide	14
Supplied Accessories	14
Appendix 1	15
Limitation of Smoke Detectors	15

AW-BK901 Conventional Reflective Beam Detector

Introduction

Overview

AW-BK901 Conventional Reflective Beam Detector has built in Laser beam pointing and Digital guide display for real user friendly alignment method. The Laser beam pointing accurately point the exact location where to mount mirror and with additional digital guide display allows to monitor and guide on the actual light intensity between the mirror and detector which cannot be seen by our naked eye making it more easy and convenient in alignment commissioning.

The AW-BK901 has four adjustable operational range of between 8 to 20, 40, 70 and 100 meters beside with three adjustable sensitivity setting ranges from 2.6 dB to 4.8 dB to meet the specific environmental requirement. The AW-BK901 works on the principle of reflective infrared beam obscuration. Used in conjunction with a reflector, it will notify the fire alarm panel when the infrared beam is obscured by smoke. Secure and quick communication through the onboard processor enables the detector to make its own decision and drift compensation resulting in greater automation.

The AW-BK901 is ideal for use at the wide areas with high ceiling such as warehouses, large storages, shopping malls, leisure centres, exhibition halls, hotel lobbies, printing houses, garment factories, museums and prisons, as well as places where slight smoke particles or corrosive gas exist.

Main Features

1. Manufacture in compliance with EN 54-12
2. Hassle free alignment, built with digital guide display and laser beam pointing
3. Employ single-ended design through reflective mirror
4. Four ranges wide monitoring from 8-100 meters via encoder
5. Three users programming sensitivity adjustment
6. Built-in microprocessor
7. Self-diagnosis function can monitor for internal faults
8. Automatic compensation for factors weakening received signals, such as dust contamination, positional movement and ageing of the transmitter
9. Fire and Fault interfacing relays
10. Attractive and pleasing appearance
11. Real User friendly alignment method

AW-BK901 Conventional Reflective Beam Detector

Technical Specification

Part Number	AW-BK901
Standard	
Listed	LPCB Pending
Compliance	EN 54-12
Fire Detection and Alarm Systems	BS 5839 Part 1:2002
Specification	
Operating Voltage	20 V to 28 V DC
Current Parameters	Standby≤ 18mA Commission≤ 55mA Alarm≤33mA
Beam Sensor Sensitivity [via Encoder]	Level 1: 2.6 dB High Sensitivity Level 2: 3.4 dB Medium Sensitivity Level 3: 4.8 dB Low Sensitivity
Beam Pathway Length [via Encoder]	Span 1: 8 to 20 meters Short Path Span 2: 20 to 40 meters Short Path Span 3: 40 to 70 meters Normal Path Span 4: 70 to 100 meters Long Path
Beam Path Angle	±0.5° Directional
Alignment Guide	Laser Beam Pointer
Digital Display Guide	Nixie Tube
LED Indicator Guide	Red: Fire ; Yellow: Fault ; Green: Alignment
Reset Time	Less than 2 Second
Relay Capacity [Fire & Fault]	Normally Open/ 2.0 A; 30 VDC
Physical	
Material / Color	ABS / White
Dimension / Weight	L:190.87 x W:126.87 x H:91.96 mm / 440 gm
Weight	0.130 Kg with base
Environmental	
Operating Temperature / Protection Rating	-10°C to 55°C / IP30 [IP66 glue seal]
Humidity	0 to 95% Relative Humidity, Non condensation

AW-BK901 Conventional Reflective Beam Detector

Product Appearance



Principle of the Beam Detector

The AW-BK901 reflective optical beam smoke detector incorporates a light transmitter and the detector on the same unit. The light path is created by reflecting light emitted from the transmitter off a retro-reflector, meaning it reflects light back to its source with a minimum of scattering, which is placed opposite the detector.

In a fire, when smoke falls within the path of the beam detector, some of the light is absorbed or scattered by the smoke particles. This creates a decrease in the received signal, leading to an increase in optical obscuration. This unit decodes or analyzes received signals and compares to the pre-programmed algorithm stored on the processor. Through this algorithm the detector will decide whether fire is defined or not and lead to enablement the corresponding relays and LED indicators. The unit on the operating mode continually emitting light, care should be taken that the activities in the space do not obstruct the beam or move the device to avoid false operation of the detector.

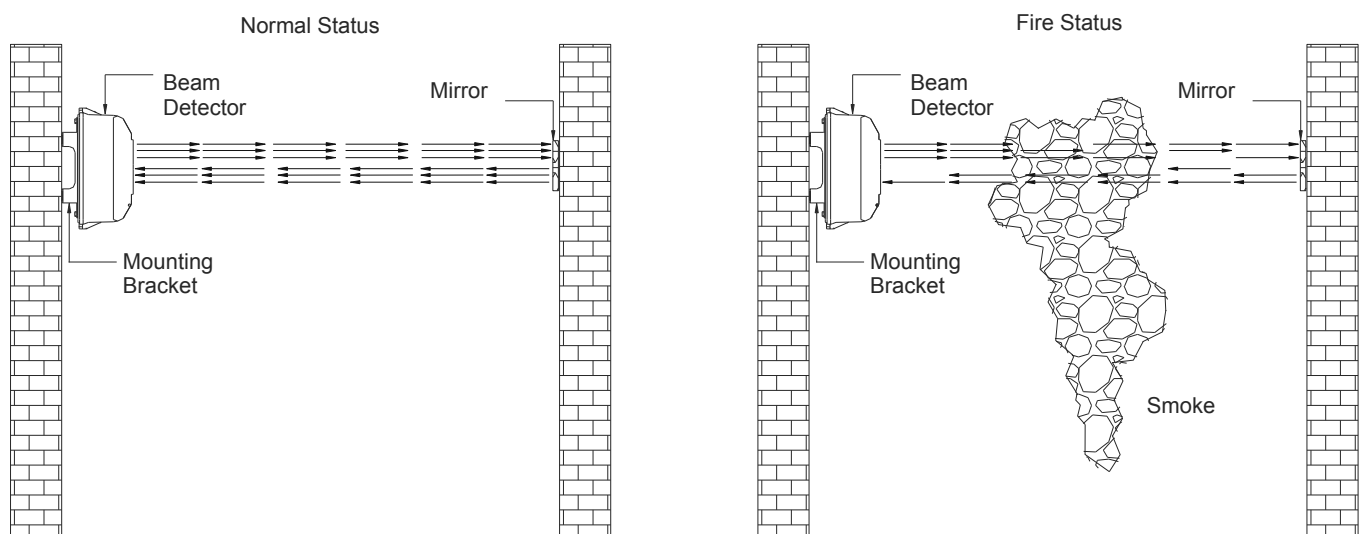

Figure 1: Beam detector principle

AW-BK901 Conventional Reflective Beam Detector

Installation Procedures

Mounting Details

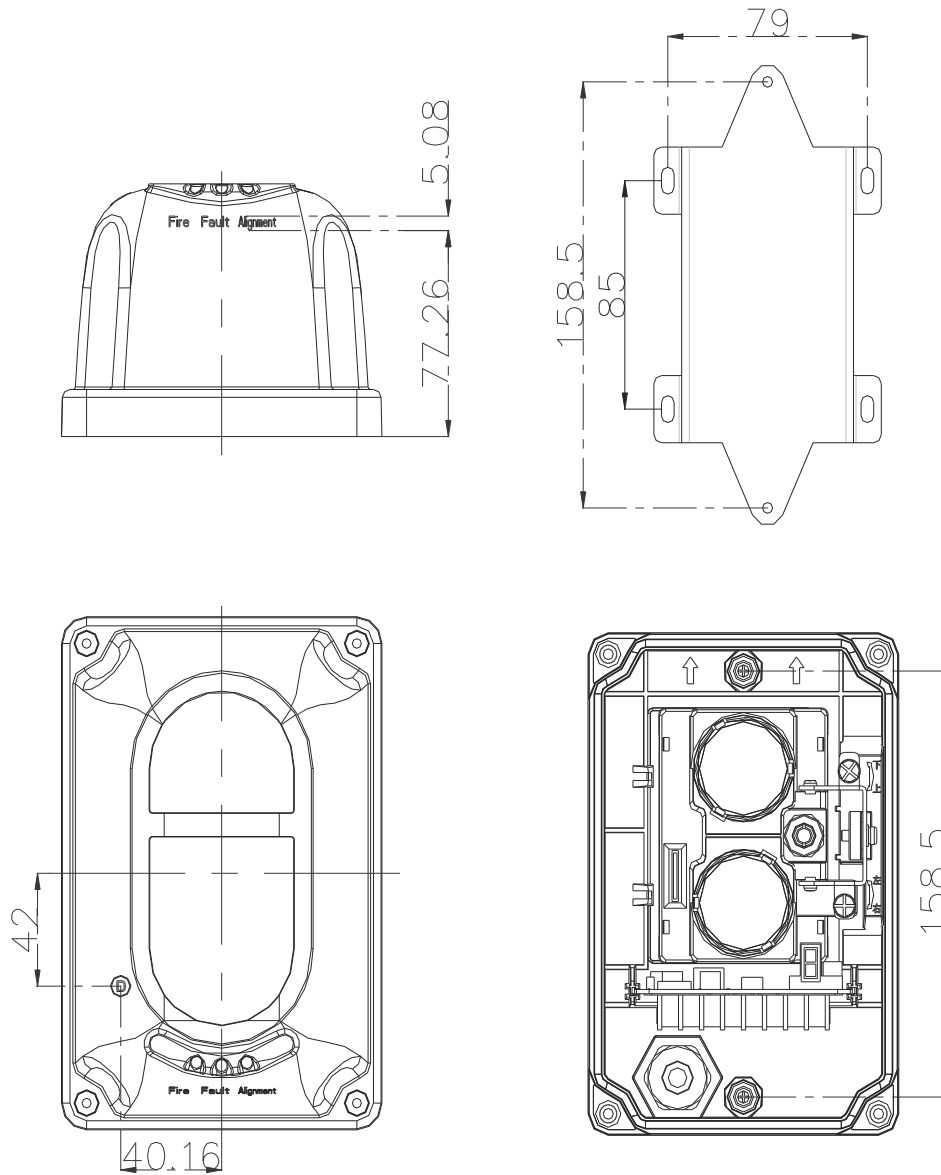

Figure 2: Detector Diagram

LED Indicators

LED Indicators	Color	Function
Fire	Red	Illuminates when at least one fire alarm event occur.
Fault	Yellow	Illuminates when at least one fault alarm event occur in the Detector
Alignment	Green	Illuminates during the commissioning

Mounting Preparation

This product should be installed, commissioned and maintained by a qualified or factory trained service personnel.

Note: The device component within the device is vulnerable specially the reed switch. It is advisable to use the magnetic tool when needed to prevent physical damage.

AW-BK901 Conventional Reflective Beam Detector

1. Under flat spare area. If the ceiling height is less than 8 meters, the beam detector should be installed 0.5 meter to 1 meter below the ceiling level. Refer to Figure 3.
2. Under flat spare area. If the ceiling height is more than 8 meters, the beam detector should be installed minimum of 0.5 meter below the top ceiling. Refer to Figure 3.
3. The chosen for the location should be clean and dry and not subject to shock, vibration or electro-statistic discharge, and free from glass wall, sunlight direction any reflective barrier.
4. Make sure that the beam path is free from obscuration against moving items.

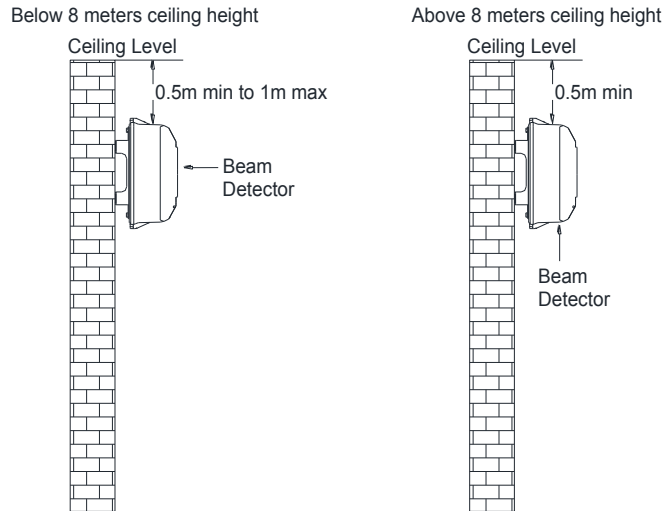

Figure 3: Installation Details

Mounting of the Beam Detector

1. Using the supplied bracket, mark the position of the fixing holes.
2. Drill four holes and insert an 8mm wall plug into each.
3. Fix the mounting bracket to the wall using four ST4x30 screw. Refer to Figure 4.
4. Fix the detector base onto the bracket using two M4x12x10 screw. Refer to Figure 5.

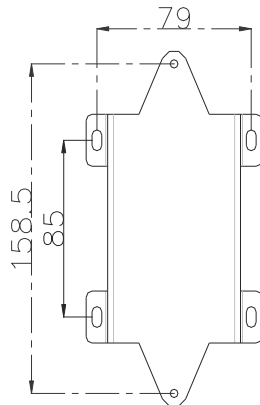

Figure 4: Mounting Bracket

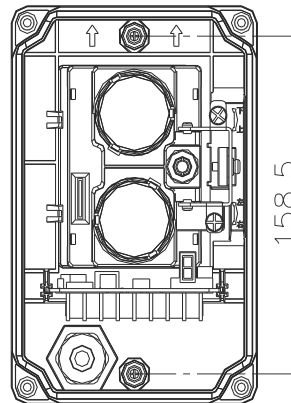

Figure 5: Beam Detector

Mounting of the Reflective Mirror

1. Depending on the project requirement, if the distance between the detector and the reflector mirror is 8m-40m, install one reflector is enough; if the distance is 40m-100m, four reflectors is required. Refer to Figure 6.
2. Mark the position of the fixing holes plastic expansion bolts.
3. Fix the reflector mirror using two ST4x30 screw, in the case of one unit mirror, do the same step for other mirror if required. Refer to Figure 6.

AW-BK901 Conventional Reflective Beam Detector

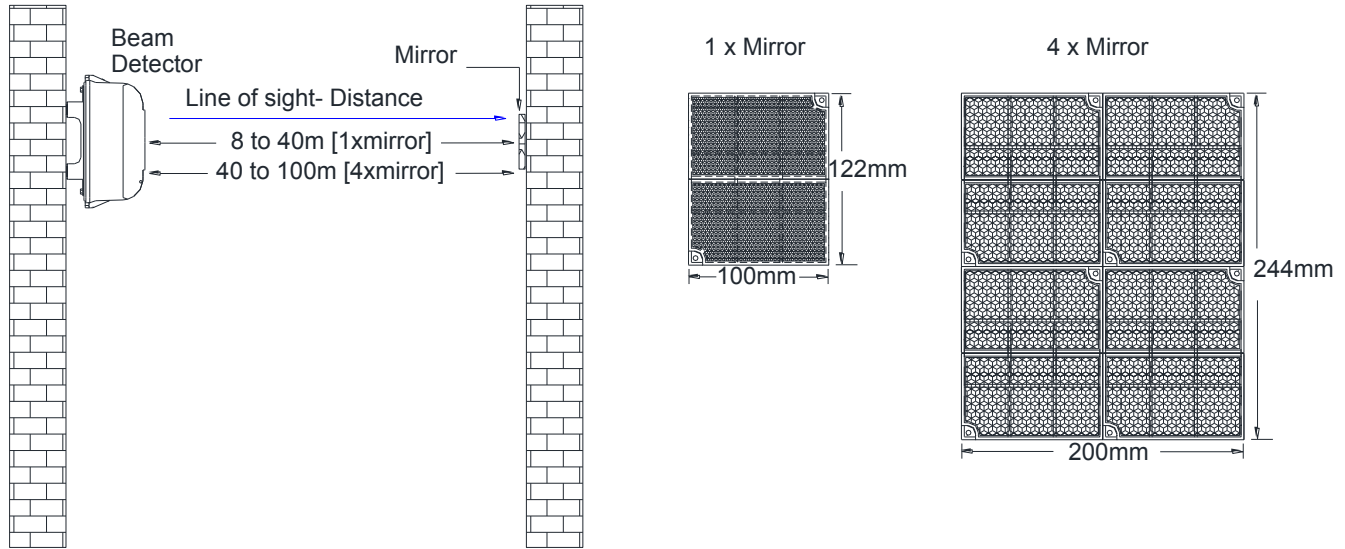

Figure 6: Mounting of Reflector Mirror

Cabling Details

Cables should be brought into the detector using the supplied glad cable. The maximum size of the cable which can be terminated is 1.5mm². Observe the polarity.

1. Terminal D1 (+) and D2 (-) for connecting Power supply [24VDC]
2. Terminal S1 and S2 for connecting handheld programmer
3. Terminal HJ1 and HJ2 for connecting Fire signal relay output [Normally Open]
4. Terminal GZ1 and GZ2 for connecting Fault signal relay output [Normally Open]

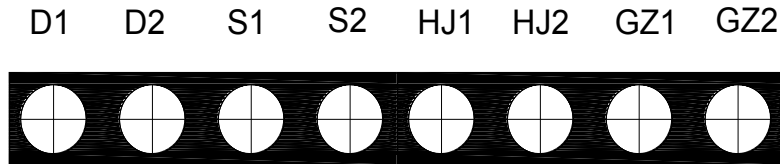

Figure 7: Wiring Terminals

Programming Sensitivity and Span

The AW-BK901 sensitivity and the operation range can be adjusted through hand held programmer on project site. The programmer can be purchased separately. It is mandatory for the commissioning personnel have programmer tool in order to adjust the detector according to the site situation and environmental requirement.

Warning: Do not power on the detector while connecting to the handheld programmer.

To View the Detector Parameter

1. Connect the programming cable to S1 and S2 terminals. Polarity is not required and detector must be powered off. Refer to Figure 8.

AW-BK901 Conventional Reflective Beam Detector

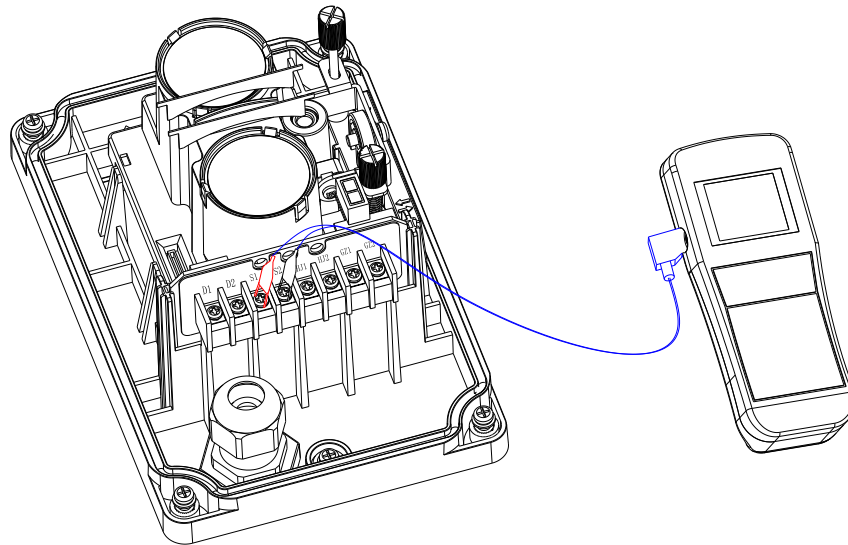

Figure 8: Connection with the programmer

2. Switch on the programmer, then press button "1" to view the address [for addressable system use only], code and sensitivity level. Refer to Figure 9.
3. Press button "Page" to view the Span parameter. Refer to Figure 9.

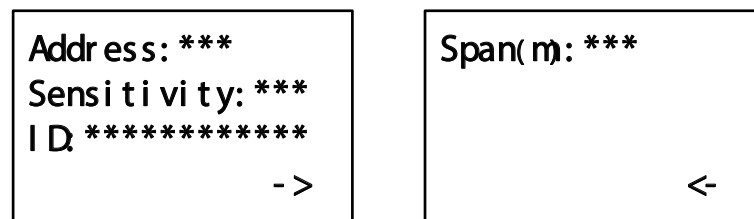

Figure 9: Interface Display

4. Press again the "Page" to return to the previous parameter
5. Press button "Exit" to clear and exit.

To adjust the Sensitivity

Connect the programming cable to S1 and S2 terminal. Polarity is not required and detector must be powered off.

Reference:

Beam Sensor Sensitivity value	Level 1: 2.6 dB High Sensitivity
	Level 2: 3.4 dB Medium Sensitivity
	Level 3: 4.8 dB Low Sensitivity

1. Switch on the programmer, then press button "3" then display "Sensitivity and Span (m)".
2. Then enter the desire sensitivity value from 1, 2, or 3 and then press "Write". If display "Success", it means the entered sensitivity is confirmed. If display "Fail", it means failure to program the sensitivity.

Factory Default Settings: Level 1: 2.6 dB High Sensitivity

To adjust the Span (Distance)

1. Connect the programming cable to S1 and S2 terminal. Polarity is not required and detector

AW-BK901 Conventional Reflective Beam Detector

must be powered off.

Reference:

Beam Pathway Length	Span 1: 8 to 20 meters Short Path
	Span 2: 20 to 40 meters Short Path
	Span 3: 40 to 70 meters Normal Path
	Span 4: 70 to 100 meters Long Path

2. Switch on the programmer, then press button "3" then display "Sensitivity and Distance (m)".
3. Then enter the desire span value from 1, 2, 3 or 4 and then press "Write". If display "Success", it means the entered sensitivity is confirmed. If display "Fail", it means failure to program the sensitivity.

Factory Default Settings: Span 3: 40 to 70 meters Normal path

Commissioning Beam Detector

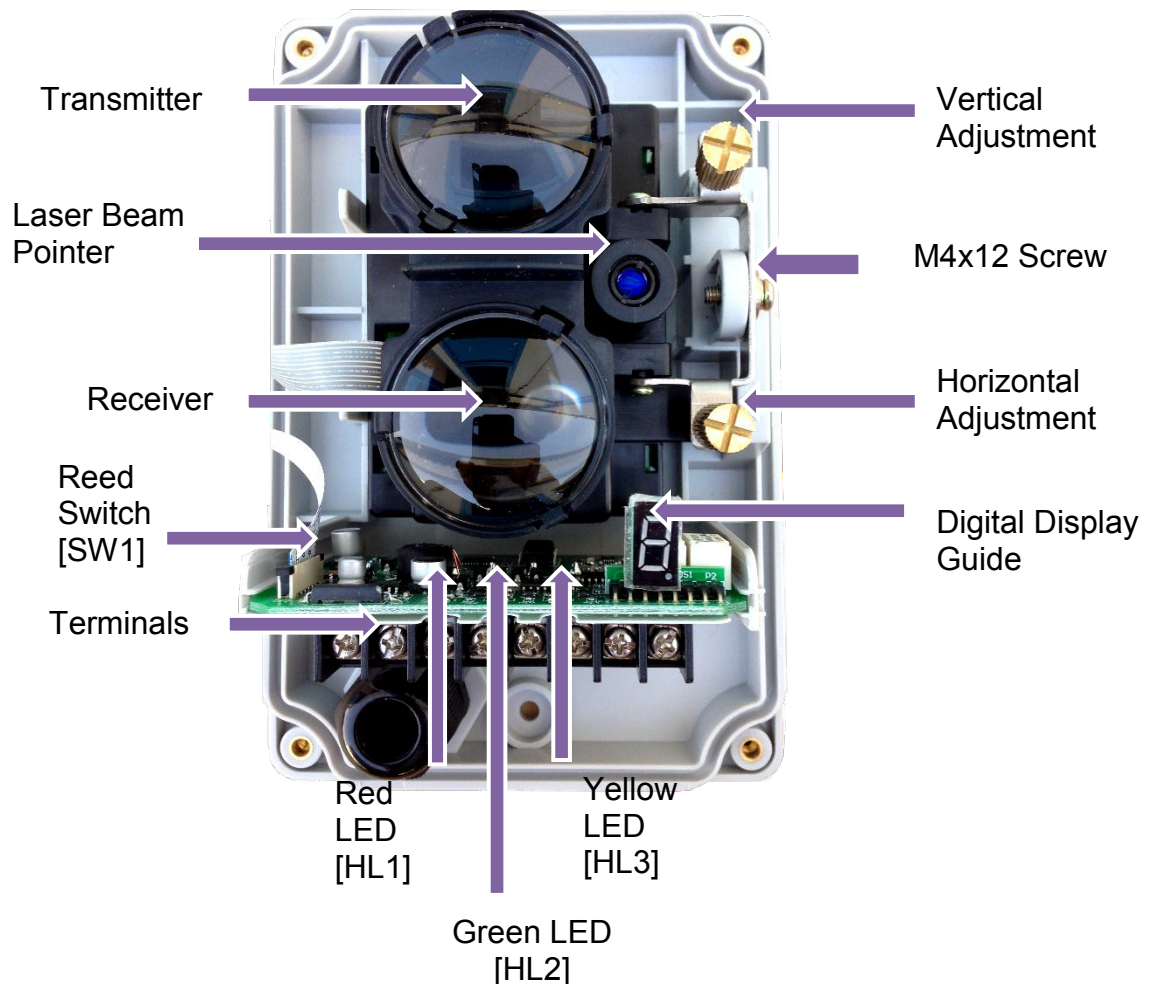

Figure 10: Detector Details

AW-BK901 Conventional Reflective Beam Detector

Commissioning Preparation

1. Make sure both beam detector and reflective mirror are properly and securely mounted.
2. Make sure that the line of sight is clear and both beam detector and reflective mirror are in placed with correct axis angle.
3. Make sure that the suitable numbers of reflective mirror are installed depending on the distance between detector and mirror.
4. Make sure required Span settings is adjusted through handheld programmer depending on the distance between the detector and mirror. [Span1:8-20meters; Span2:20-40meters, Span3:40-70meters, Span4:70-100meters].
5. Wiring should be done correctly.

Step 1: Entering Commissioning Method

- a. Remove the detector cover and power on the device.
- b. Place the supplied magnetic tool alongside the Reed Switch [SW1]. After a while the Green LED [HL2] should be on steady or blinking, and then take out the magnetic tool to start the detector auto alignment process.

Note: Keep the line of sight clear between the detector and mirror. Do not disturb the detector auto alignment process.

Step 2: Sightline Alignment Procedure

- a. The Laser Beam Pointer should turn on automatically. Look through on the reflective mirror to see if the laser beam mark is at the center of the mirror.
- b. Once you locate the mark, loosen the M4x12 screw and adjust the horizontal or vertical adjustment wheel until the Laser beam mark at the center of the mirror. Refer to figure 10.

Note: During the adjustment period the digital display guide indicates number- it is not indicating the signal intensity. If the number is turned to zero [0] it means the Sightline Adjustment is not appropriate and more adjustment is required.

Step 3: Acceptable Adjustment Procedure

- a. Adjust the signal intensity through the horizontal or vertical adjustment wheel while the detector is monitoring signal intensity through digital display guide, the number is indicating the signal intensity form 1 to 8. Try to reach number eight [8] to have an acceptable adjustment. Make sure that the line of sight is clear between the detector and mirror.

Note: If number nine [9] is displayed, it means the setting of the Span is not appropriate. In this case, power off the detector and re-program the appropriate distance between the detector and mirror through programmer.

- b. If Green LED [HL2] is steady on, it means that the signal intensity is acceptable.
- c. Tighten M4x12 Screw, and then ready to proceed to the next step.

Step 4: Finalizing Installation

- a. Insert the detector cover and screw the 4 sides of the detector.
- b. Place the magnetic tool alongside the "(D)" marked.
- c. Right after the Green LED [HL2] is off, take out the magnetic tool to allow the detector to exit from commissioning mode and turn to monitoring mode.

Warning: Do not obstruct or interrupt the signal between the detector and mirror.

Note: The Yellow LED [Fault] and Green LED [Alignment] will begin blinking simultaneously for about 3 seconds and then Red LED [Fire] will begin blinking every 3 seconds, which indicates that the beam detector is commissioned successfully.

Keep the detector run for at least 20 seconds then proceed to the next step.

Step 5: Testing Fire Signal

- Using supplied Opaque/Translucent materials, block the half of the beam detector with the translucent portion of the material. With less than 30 seconds the Red LED [Fire] will turn on steady, indicating Fire signal. [The fire alarm relay [HJ1 and HJ2 will latch to normally close]. Refer to Figure 11.
- Remove the testing material and cut the power off for at least 2 seconds to reset the detector.

Step 6: Testing Fault Signal

- Using supplied Opaque/Translucent materials, block the half of the beam using the opaque portion of the material. Right after the Yellow LED [Fault] turns on, indicating the fault signal. [The fault alarm relay GZ1 and GZ2] will latch to normally close]. Refer to Figure 11.

Note:

- If the opaque material is taken away from the detector in less than 15 seconds, then the detector automatically reset to normal status.
- If the opaque material is not taken away from the detector and is maintained for more than 15 seconds, then a fire signal is registered, in this case, cut the power for at least 2 seconds to reset the detector.

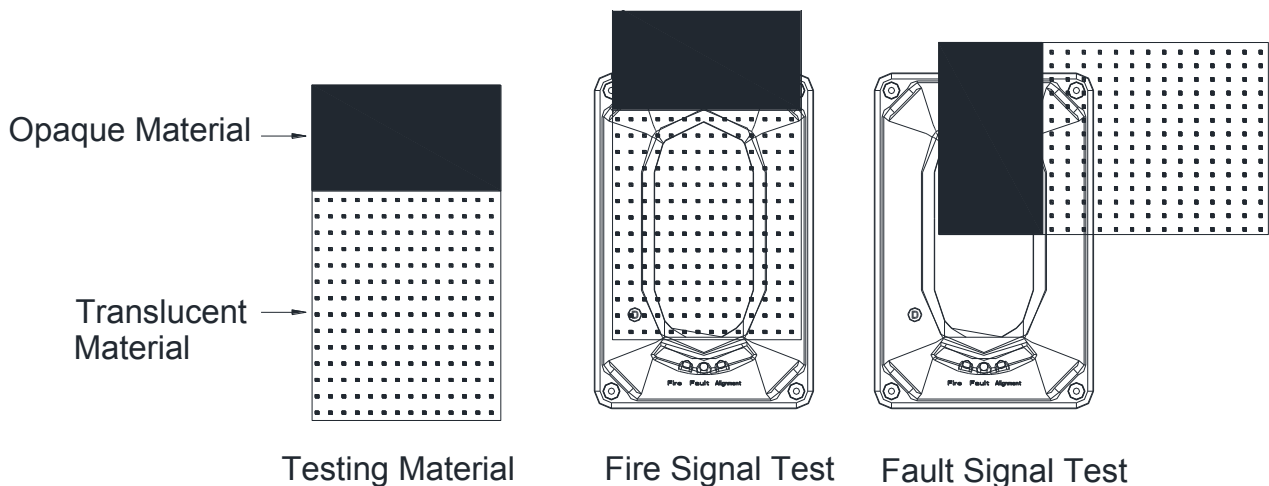

Figure 11: Testing Details

Other Function

Automatic Compensation of Light

When dust exists in the working environment of the detector, the emitting window, receiving window and reflector will be covered with dust, which will affect normal operation. In order to solve the problem, we designed the function of automatic compensation of light. When there is dust on windows, the detector can judge the amount of dust, and compensate the received signal through internal program and circuit to ensure the detector can continue to work normally. The detector gives fault signal when dust on the lens and reflector surface reaches a certain level and light compensation reaches the limit for the detector to work normally.

Self-diagnosis on Optical Signal

The detector has functions of checking emitting, receiving and amplifying circuit. When there is fault with these three parts of circuit during operation, the detector will generate fault information.

Maintenance

1. Inform the proper personnel before conducting maintenance.
2. Disable the detector on the control initiating equipment to prevent false alarm.
3. Clean the outer housing specially the glass portion of the detector. Wipe with soft cloth carefully. Do not use cleaning chemical.
4. Inform the again proper personnel after conducting the maintenance and make sure to enable the detector and check if up and running.
5. Perform the maintenance semi-annually or quarterly depending on the site condition.

Troubleshooting Guide

Trouble	Comment	Troubleshooting Advice
Indicates Faults after commissioning	The detector is Dirty The line of sight between detector and mirror was moved Not properly commission at the start	Conduct maintenance Re-Commission the detector
Unable to commission	Transmit/Receive diode is not working The reed switch is damaged	Replace the component.
Keep Indicating Fire signal	Check if vibration or electro-statistic discharge is preset after commissioned	Re-Commission the detector
Fire signal can't be cleared	There are obscuration on the optical pathway between the detector and the reflector. The angle of optical pathway has changed and need to be aligned again.	Re-Commission the detector

Supplied Accessories

The following accessories are included in the package:

1. Four plastic expansion bolts.
2. Two M4*12*10 three combination cross recessed pan head screws.
3. Four ST4*30 tap cross recessed pan head screws.
4. Mounting Bracket
5. Opaque/Translucent Material
6. Six Ø4 flat washers.
7. Magnetic Tool

Appendix 1

Limitation of Smoke Detectors

The smoke detector is designed for triggering and initiating emergency fire equipment's, but it only functions when matching with other equipment's. Installation of this smoke detector must conform to electrical codes and standards in your country.

All types of smoke detector have limitations. Because fires develop in different ways and are often unpredictable in their growth, it is impossible to predict which type of detector will provide the earliest warning. No types of smoke detector can sense every kind of fire every time. Generally speaking, detectors may not warn you about fires caused by insufficient safety measures, violent explosions, leaking gas, improper storage of flammable materials like diluents and other safety hazards, arson or children playing with fire. The alarm of a smoke detector used in high velocity environment will be delayed due to dilution of smoke by frequent and fast airflow. What's more, the smoke detector has to be maintained frequently because there will be more dust contamination.

The smoke detector cannot last forever. In order to keep the detector working in good condition, please maintain the equipment continuously according to recommendations from manufacturers and relative nation codes and laws. Take specific maintenance measures on the basis of different environments. The smoke detector contains electronic parts. Even though it's made to last for a long period of time, any of these parts could fail at any time. Therefore, test your smoke detector at least every half-year according to national codes or laws. Any smoke detectors, fire alarm devices or any other components of the system must be repaired or replaced as long as they fail.